

Standard Type

Pneumatic Score Knifeholder

MT-A110

MT-A110 is one of the most versatile and flexible crush knife-holder for crush slitting. It works against the hardness anvil roller. Modular designed knife-holder has advantage of excellent rigidity which can accept 6kg/cm² air pressure and provide stable down force to perform various material slitting job. It can replace score blade/zig zag blade/k dash blade/wave blade for different slitting application. MT-A110 is using screw method to fix on guide-bar which is compatible with guide-bar GB01/GB02/GB04.

Because of its versatility, MT-A110 is widely used in light rubber, paper, cloth, plastic film...etc.

» Feature

- Min slitting width 12mm
- Unibody knifeholder
- Stable down force provide
- Economy model
- Screw type fix method

» Specification

- Min. slitting width : 12mm
- Max. slitting speed : 100M/min ⁽¹⁾
- Down stroke range : 0~15mm
- Max. air pressure : 6kg/cm²
- Blade dia. : ø76.2mm
- Guide-bar : GB01/GB02/GB04

Patent Number
Taiwan 83675 /Germany 29500315.4 / Japan 3013675
China ZL93218144.9 / U.S.A. 5551328

(1)Max slitting speed depends on different material and the condition will be changed.



MT-A110

MOTOKNIFE



MT-A110 Dimension drawing

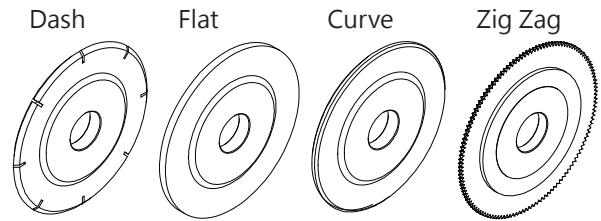
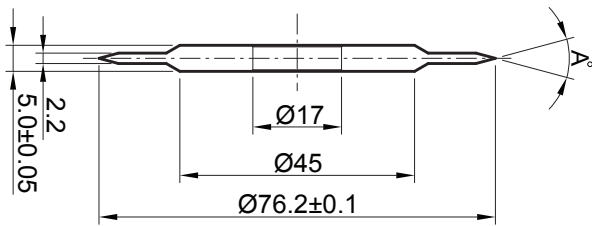
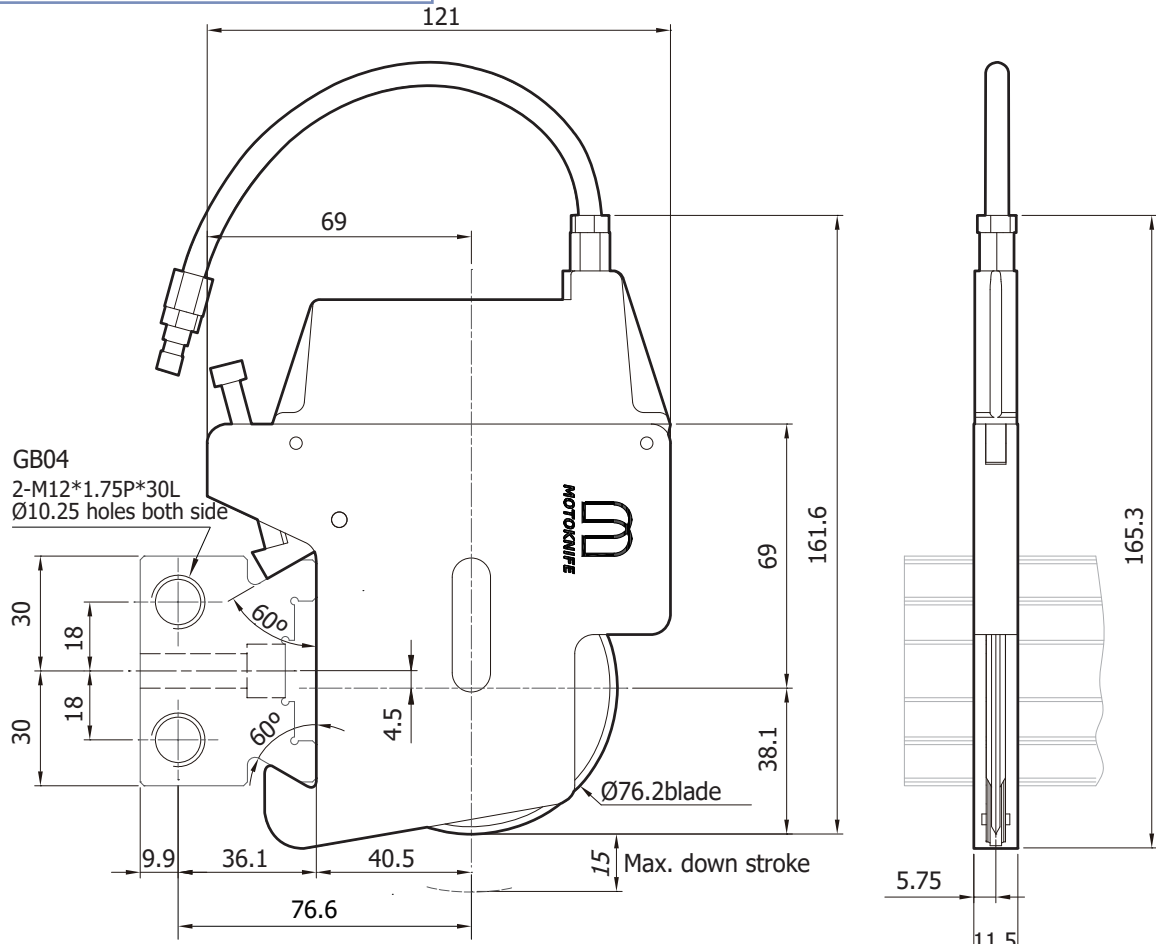

Product code	Material	Angle(A)	Hardness
BS-K-076-017-050-D30	SKD-11	30°	HRC60~62°
BS-K-076-017-050-D60		60°	

Various Papers	kraft paper, silicone paper, releasing paper, decoration wall paper, masking paper, adhesive paper, thick paper board, corrugated carton paper, sand paper.
Various Plastic films	flexible laminated films, soft & rigid PVC films, BOPP, PET, PE, PS, LDPE, PLA, SBS, various adhesive tape...etc.
Cloth & fabrics	non-woven cloth, synthetic leather, natural cotton, mesh cloth, medical cloth, label cloth...etc.
Foams	PSP foams, PE foams...etc.

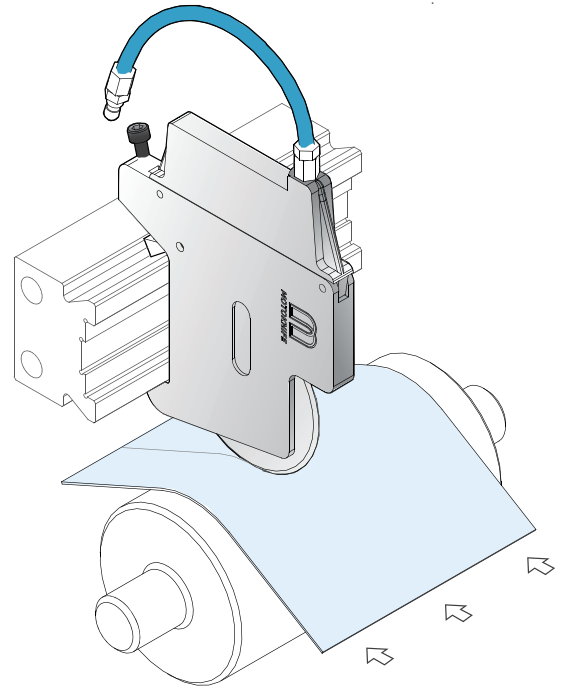

MT-A110

MOTOKNIFE



MOTO INDUSTRIES CO., LTD.
 32652 No.65 Lane 155, Xinjiang Rd.,
 Yangmei District, Taoyuan City, Taiwan
 TEL:+886-3-4753005
 FAX:+886-3-4754797
 E-mail:service@motoknife.com
 http://www.motoknife.com

MOTO(SHANGHAI) MACHINERY CO., LTD.
 No.240, Lane 2999 Baoangong Road,
 Jiading District, Shanghai City, China
 TEL:+86-21-69596169
 FAX:+86-21-69596163
 E-mail:motokevin@126.com



Standard Type

Pneumatic Score Knifeholder

標準型氣動分條刀組

MT-A110

MT-A110 標準型氣動分條刀組為壓切式分條應用，需要硬輪做為背輪，本體採用模組化一體成型設計，具有良好剛性及強度，刀組最高可承受6KG/CM²氣壓壓力，可以輕鬆應付各種低速分切場合。在不同需求下可搭配各式刀片如標準圓刀/K線刀/齒形刀/波浪刀等。刀架固定方式採用螺栓固定，可搭配GB01/02/04鳩尾座使用，亦可選購尺規板來減少排刀時間及降低人工排刀尺寸誤差。

MT-A110標準型氣動分條刀組主要是廣泛應用於橡膠類、不織布、紙類、布類及塑膠膜類等較薄材質的低速分條場合。

》 特色功能

- 最小分條寬度 12mm
- 一體成型刀架本體
- 經濟型壓切刀組
- 刀組為螺絲固鎖式

》 刀組規格

- 最小分條寬度 :12mm
- 最大分條速度 :100M/min_(註1)
- 下刀行程範圍 :0 ~ 15mm
- 最大供給空壓 :6kg/cm²
- 刀片尺寸 :ø76.2mm
- 選配鳩尾座 :GB01/GB02/GB04

專利號碼：

Taiwan 83675 /Germany 29500315.4 / Japan 3013675

China ZL93218144.9 / U.S.A. 5551328

註1: 最大分條速度依實際分切不同材料及條件為準



MT-A110

MOTOKNIFE



MT-A110 刀組尺寸圖面

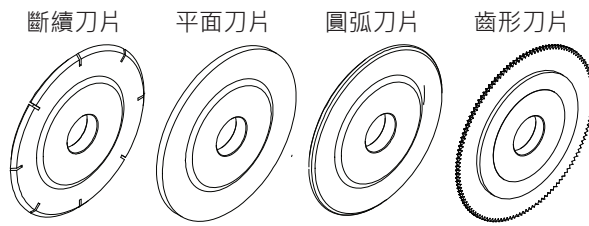
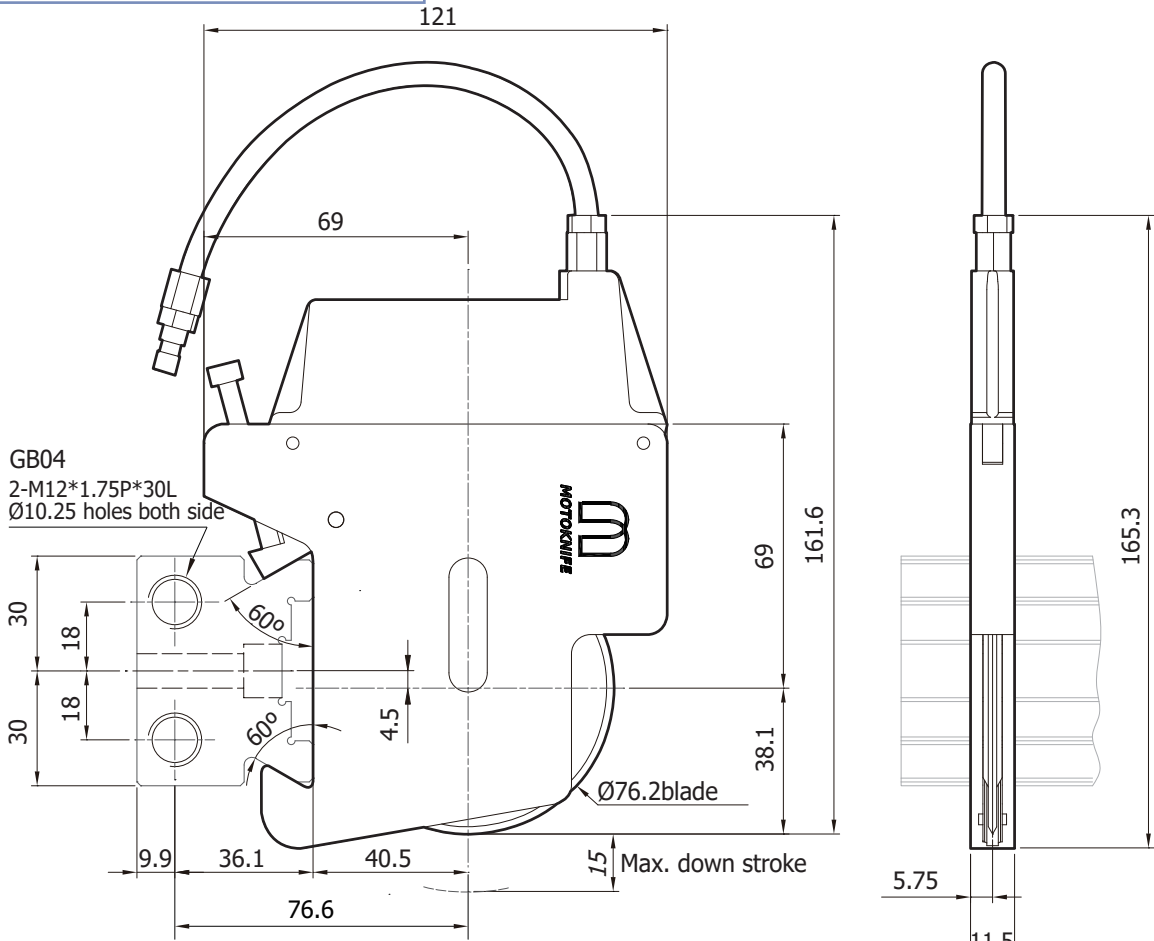

產品編號	材質	角度(A)	硬度
BS-K-076-017-050-D30	SKD-11	30°	HRC60~62°
BS-K-076-017-050-D60		60°	

適用分條產品

紙類	牛皮紙、離型紙、壁紙、美紋紙、膠帶、瓦楞紙板、砂紙
塑膠模類	軟質 PVC、硬質 PVC、PP、PE、PS、LDPE、PLA、SBS、膠帶
布類	不織布、合成皮布、天然棉布、紗布、藥膠布、商標布
發泡類	泡棉、發泡布

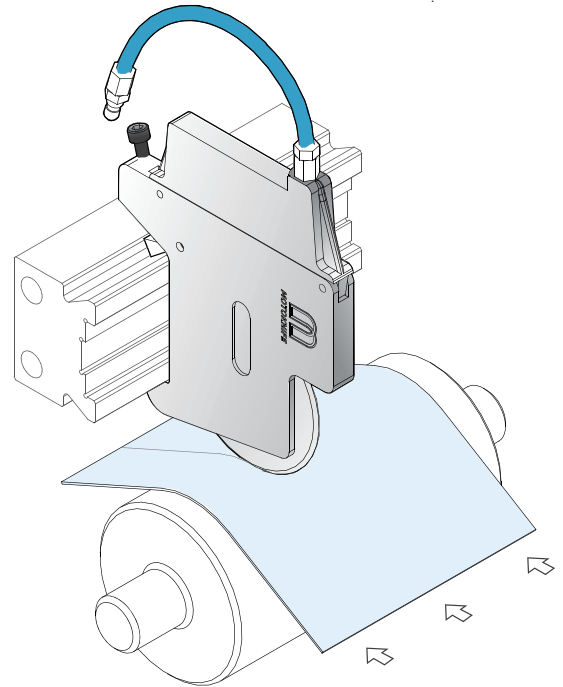

友聚工業有限公司 (台灣總公司)
32652 桃園市楊梅區新江路155巷65號
電話:+886-3-4753005
傳真:+886-3-4754797
E-mail:service@motoknife.com
http://www.motoknife.com

友聚 (上海) 精工機具有限公司 (上海分公司)
上海市嘉定區馬陸鎮寶安公路2999弄240號
電話:+86-21-69596169
傳真:+86-21-69596163
E-mail:motokevin@126.com



MT-A110

MOTOKNIFE